

FONTE CHAVEADA

Modelo		HB-S15	HB-S25	HB-S35	HB-S40	HB-S50	HB-S60	HB-S100	HB-150	HB-S200	HB-350	HB-S500	
Saída	Tensão de saída	24Vcc											
	Tolerância	±2%	±2%	±1%	±1%	±1%	±1%	±1%	±1%	±1%	±1%	±1%	
	Corrente de saída	0,7 A	1,1 A	1,5 A	1,8 A	2,1 A	2,5 A	4,5 A	6,5 A	8,3 A	15 A	20 A	
	Potência nominal	15W	25W	35W	40W	50W	60W	100W	150W	200W	350W	500W	
Entrada	Tensão de alimentação	110 ou 220Vca											
	Frequência	47-63Hz											
	Eficiência	72%	80%	78%	78%	82%	79%	84%	85%	83%	81%	85,5%	
Ambiente	Temperatura de operação	-10°C ~ +60°C											
	Temperatura de armazenamento	-20°C ~ +85°C											
	Umidade relativa	20~90%											
Proteção	Sobrecarga	105~150% da potência nominal de saída										105~135% da potência nominal de saída	
	Sobretensão	27,6 ~ 32,4V							30 ~ 34,8V		26,4 ~ 32,4V		27,6 ~ 32,4V
Ventilação		Convencional/ambiente									Forçada/Ventoinha interna		
Fixação		Direta											

Dimensões

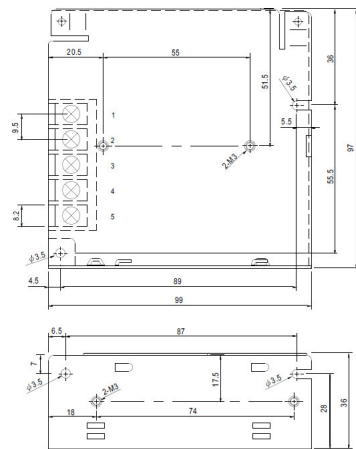

HB-S15/HB-S25

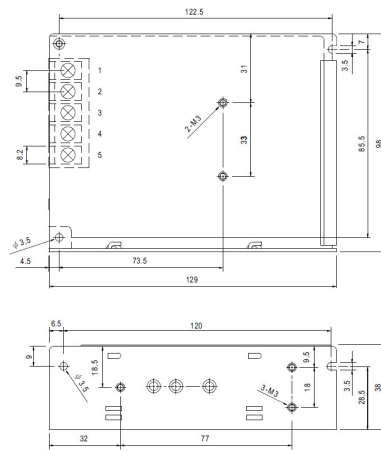

HB-S30/HB-S40

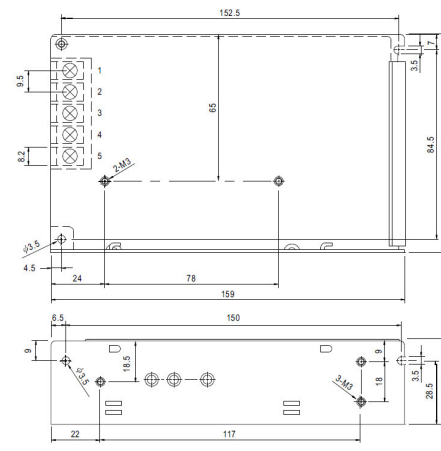

HB-S50/HB-S60

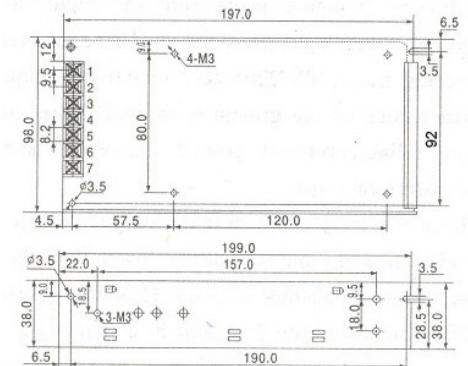

HB-S100

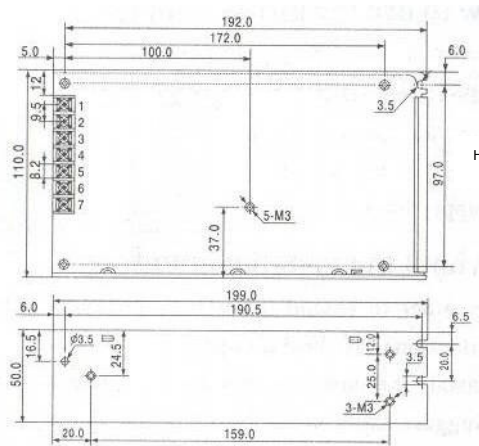

HB-S150

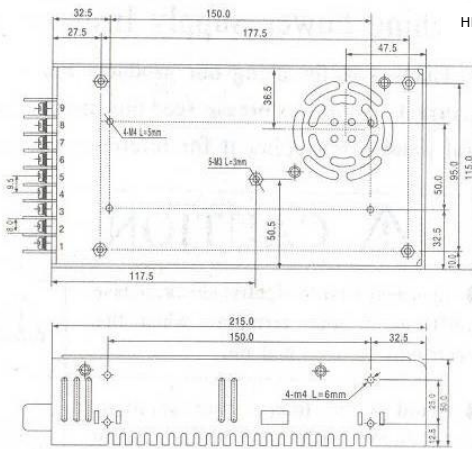

HB-S200/HB-S350

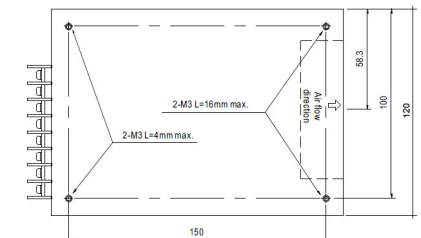

HB-S500

